

All works to be carried out in accordance with accredited construction details. The contractor is to ensure these details are fully known and understood before commencement of works. As lack of knowledge or understanding of these details will not be accepted.

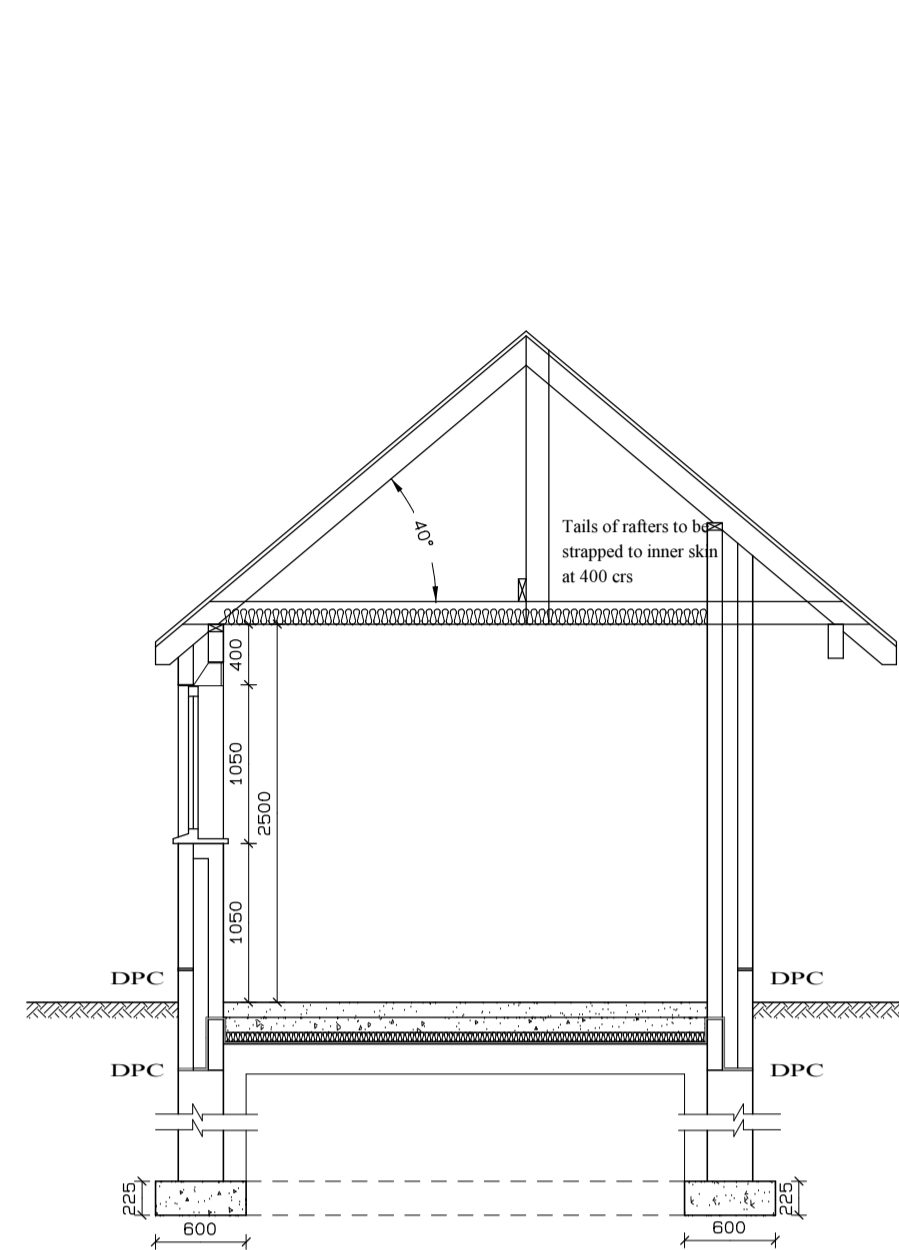

Section A-A

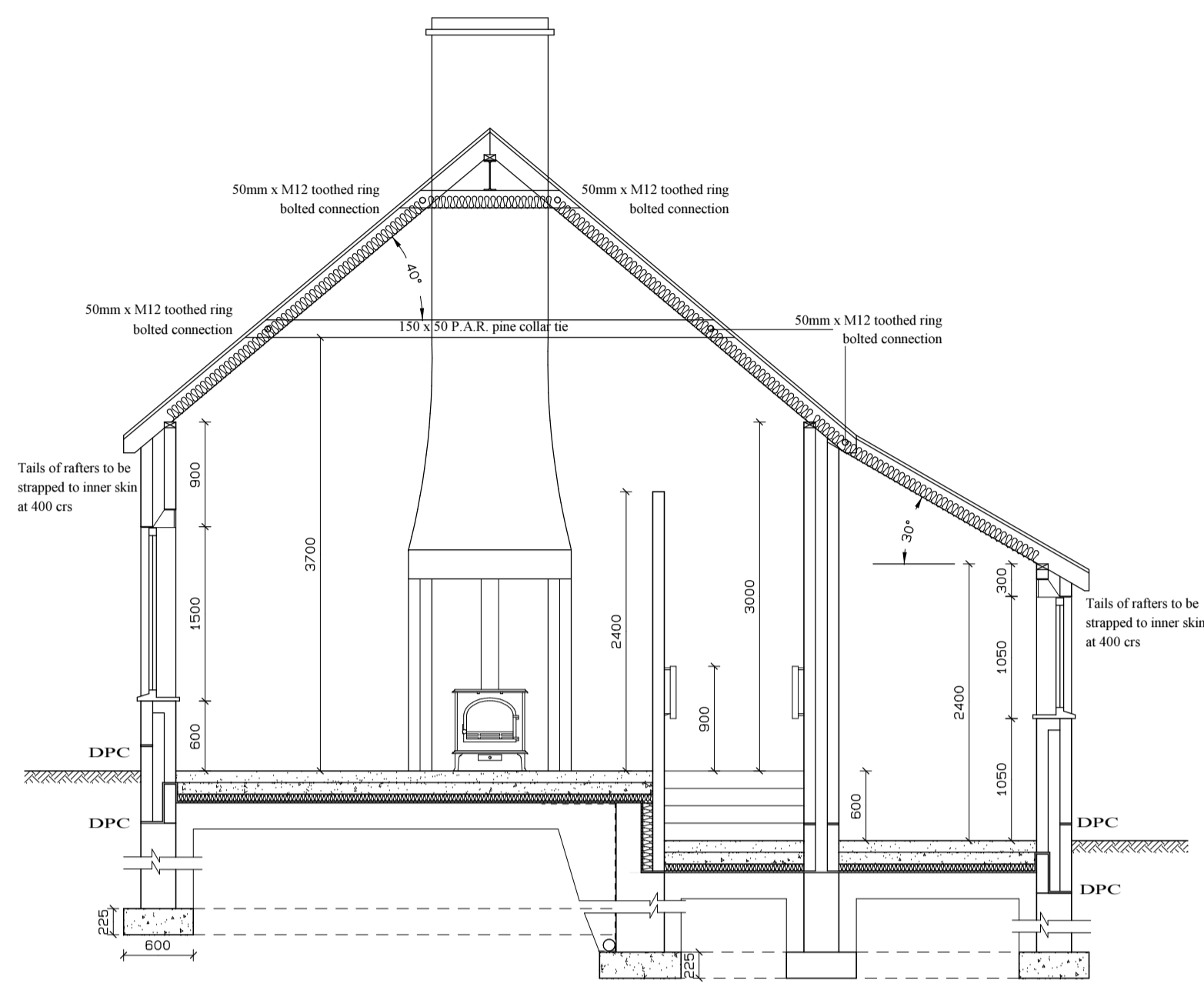

Section B-B

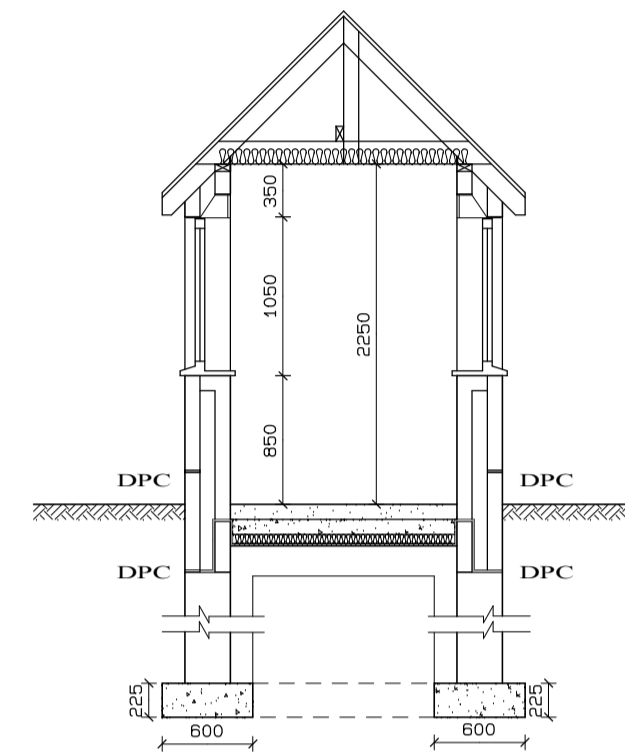

Section C-C

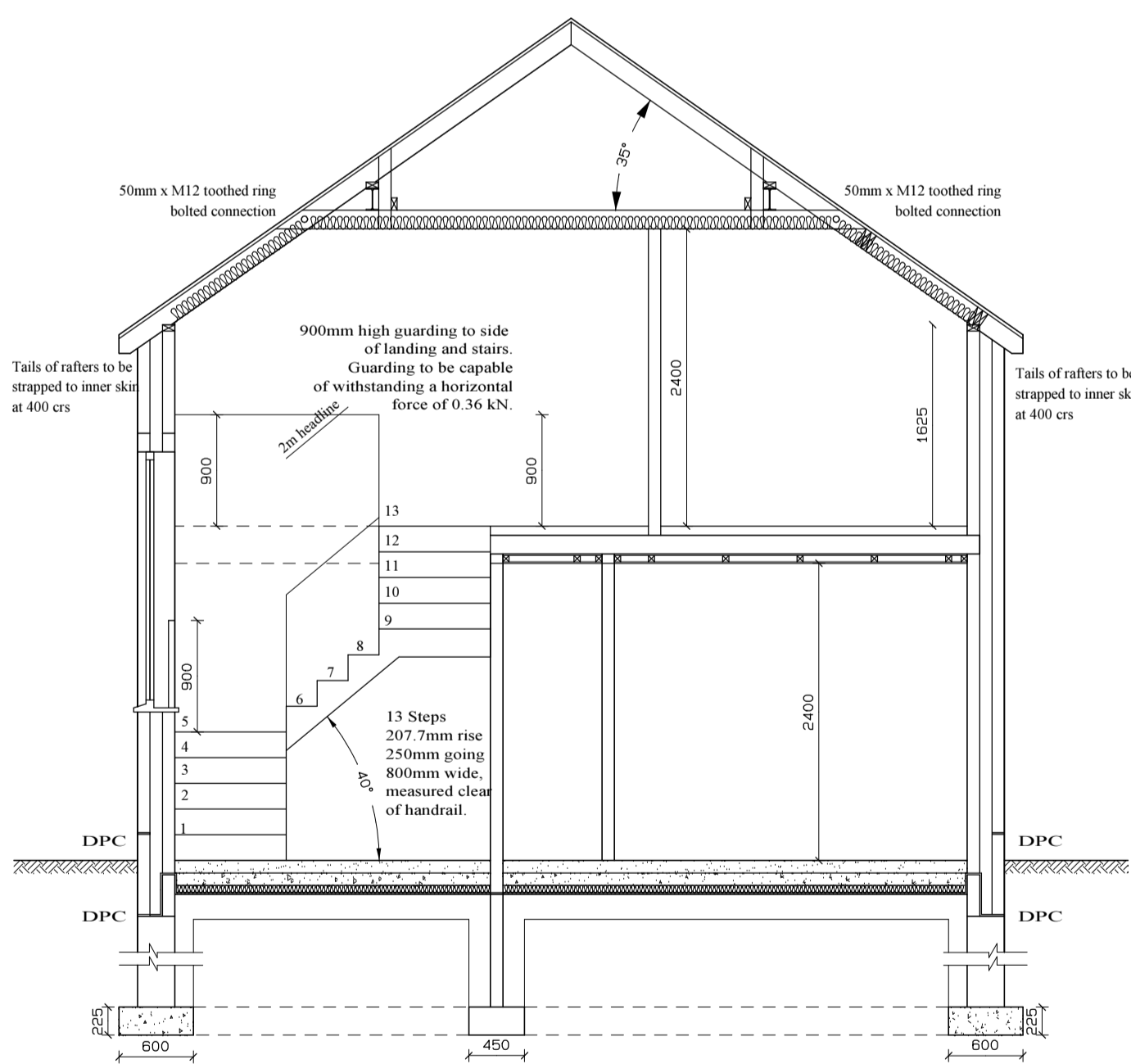

Section D-D

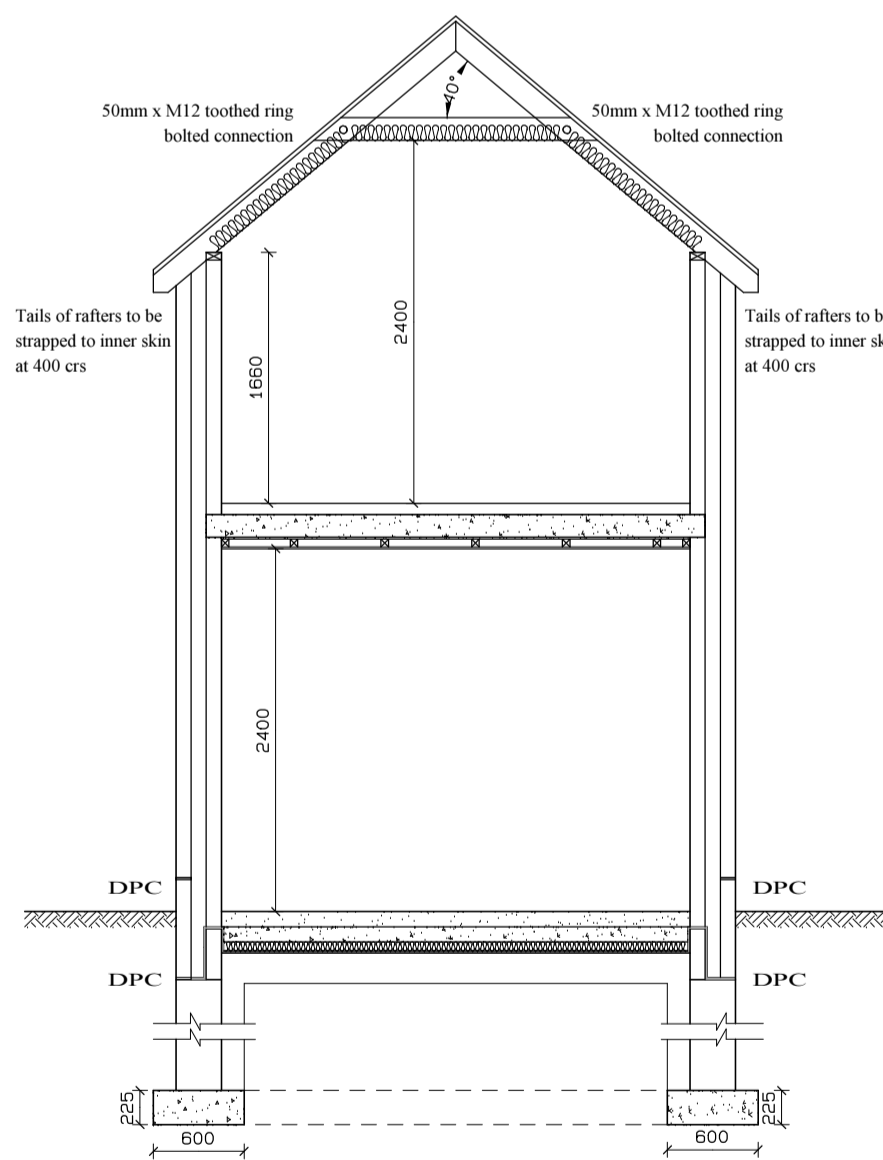

Section E-E

TANKING DETAIL.

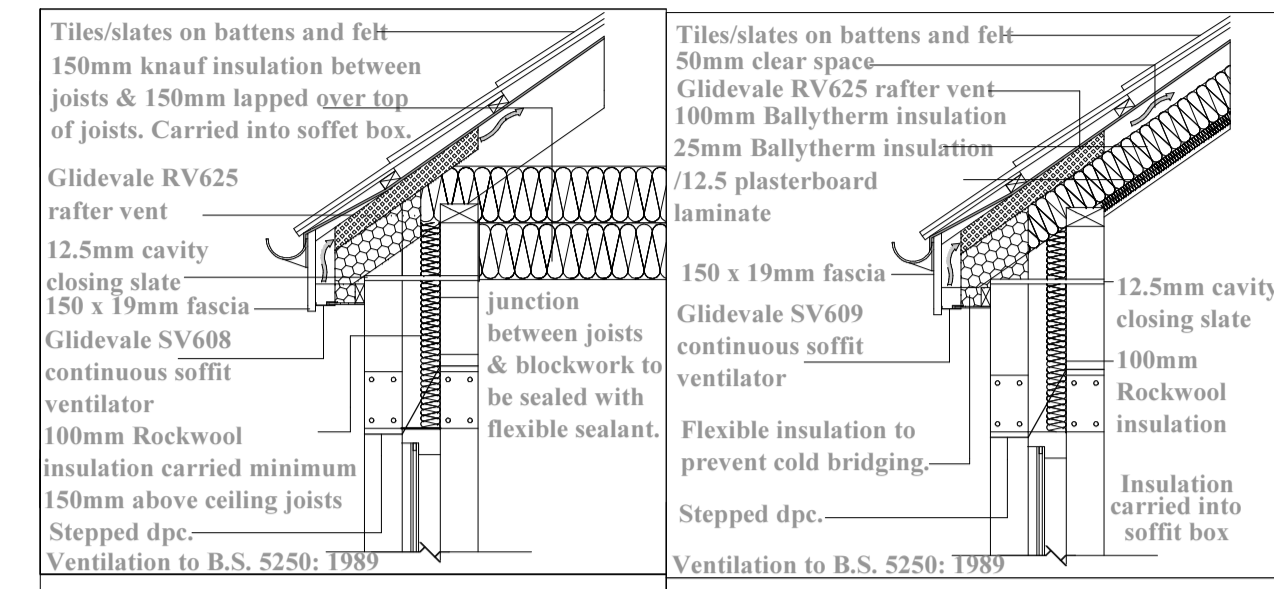
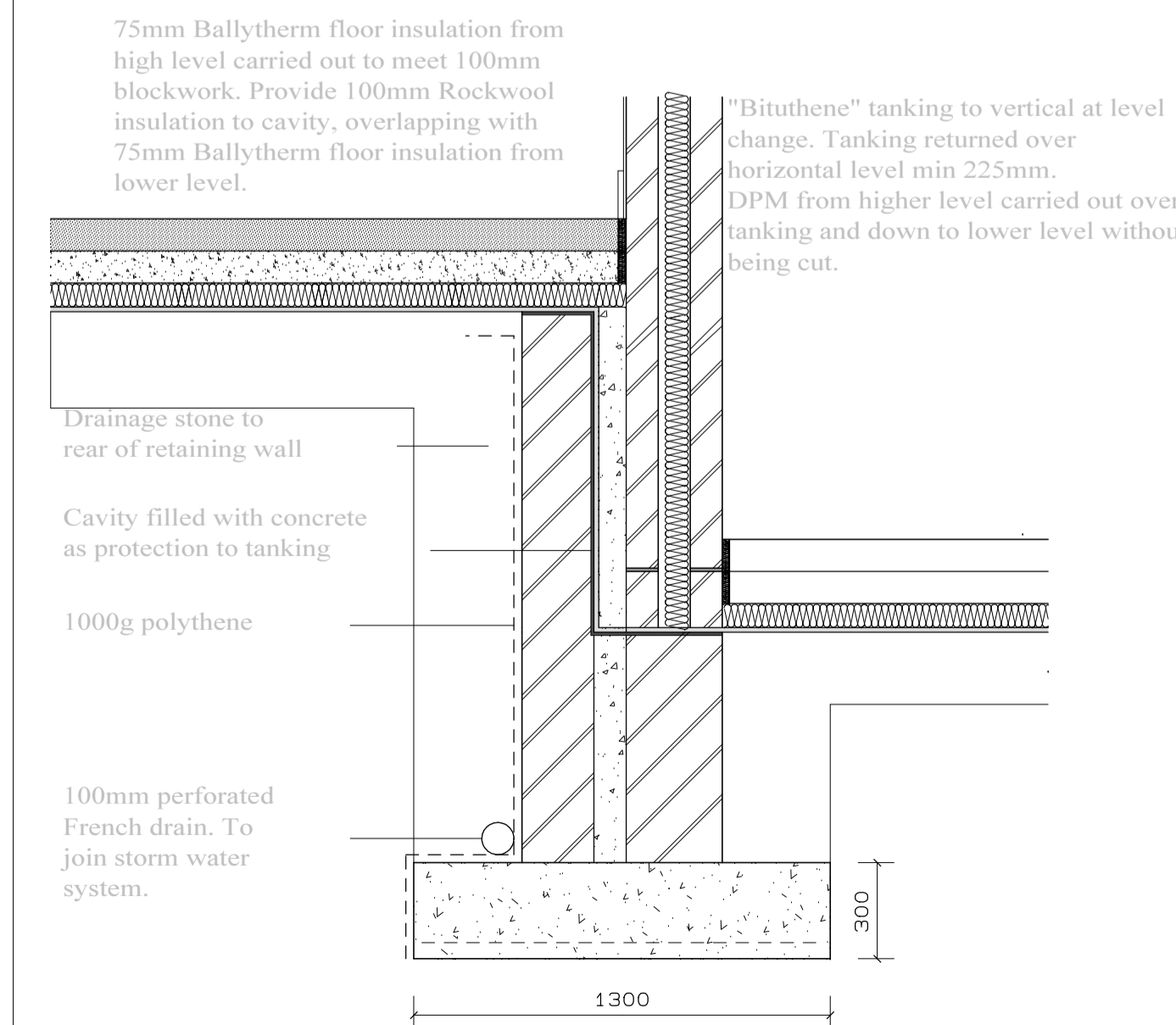

PORCH EAVES DETAIL

EAVES DETAIL

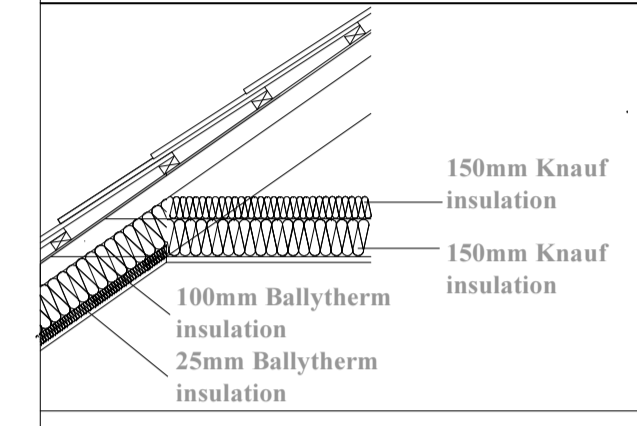

ROOF INSULATION

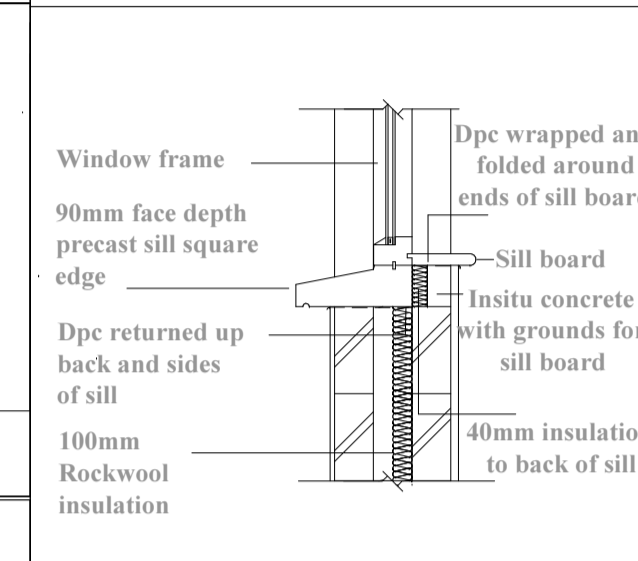

SILL DETAIL

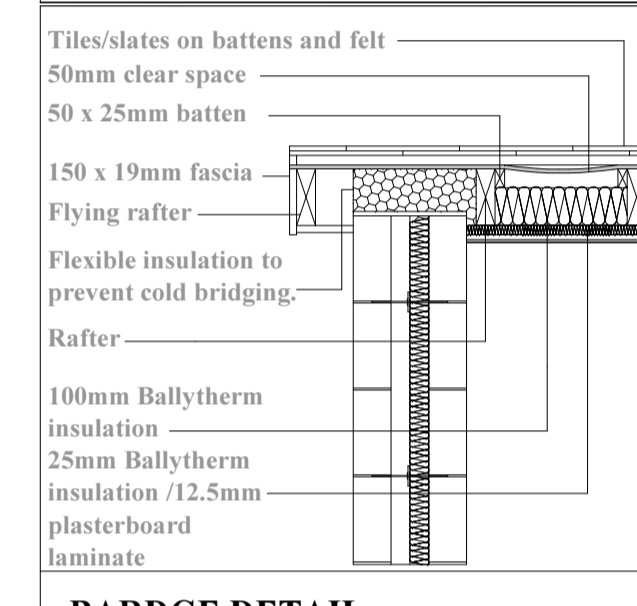

BARDGE DETAIL

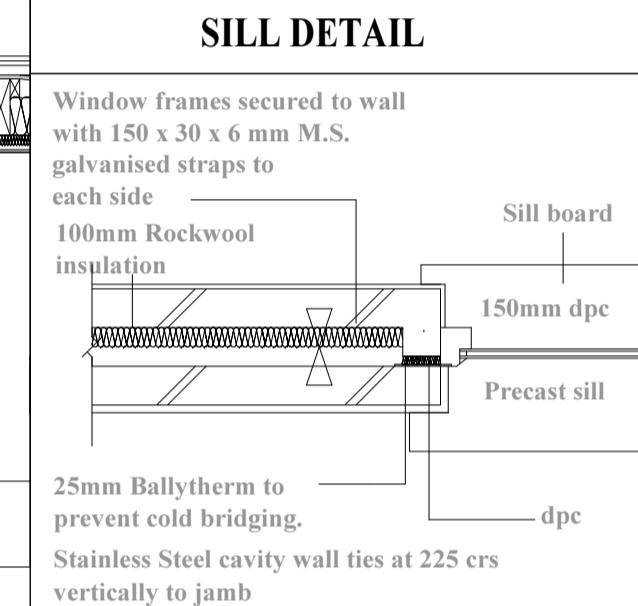

JAMB DETAIL

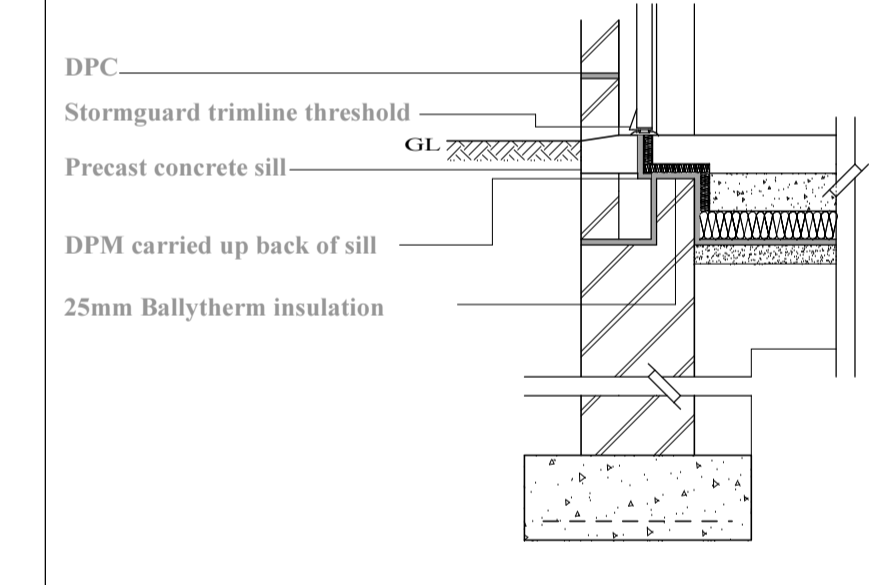

DPM DETAIL THRESHOLD DETAIL

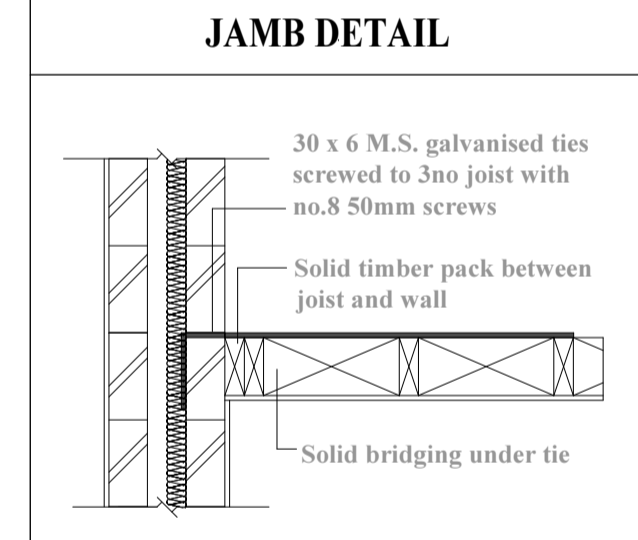

LATERAL RESTRAINT DETAIL

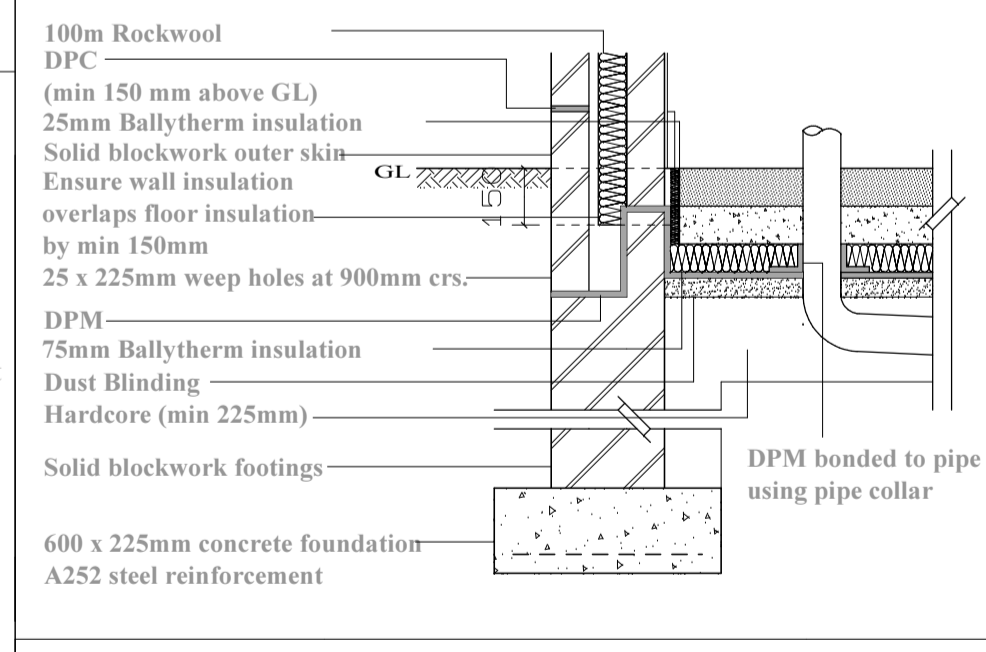

FLOOR INSULATION & DPM DETAIL

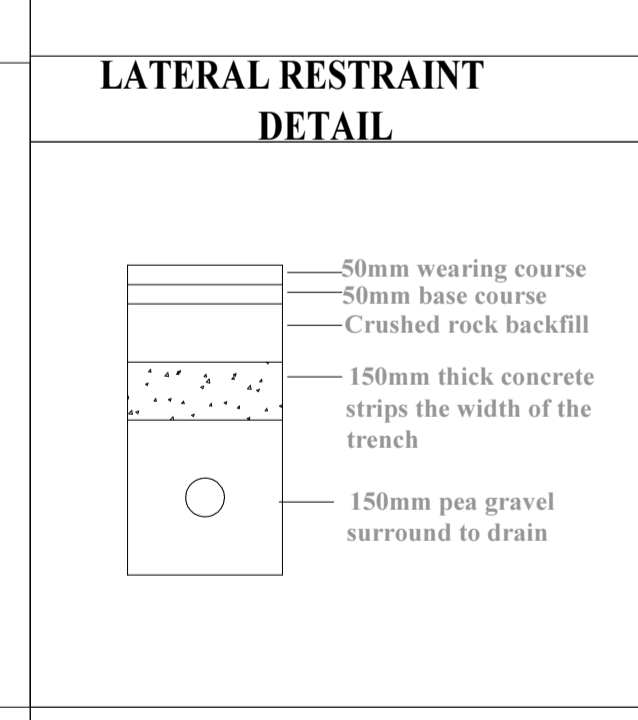

PROTECTION TO DRAINS

Planning Service Ref:				
Building Control Ref:				
Rev	Date	Description	DB	CB

© Copy Right Reserved			
PROJECT:	Erection of dwelling and domestic garage at Scribbage, Garrison, Co. Fermanagh	D.B:	CHK
CLIENT:		R.M.	No. 39
DRAWING:	Sections & Details	No.	5/7
SCALE:	1:50	DATE:	2008
DESIGNED:	RONAN MURPHY Craft Village, Main St., Belleek, BT93 3FX Tel/Fax: 028686 58190 e-mail: info@murphybuildingdesign.com		